

COMPOSITE ROOF SYSTEM WITH STANDING SEAM II

1. PRODUCT NAME

Composite Roof System for roof applications.

2. MANUFACTURER

ARCHITECTURAL METAL SYSTEMS

1150 State Docks Road
Eufaula, Alabama 36027
Phone: (334) 687-2032

3. PRODUCT DESCRIPTION

These standing seam panels float on a system of sliding clips that prevent damage from thermal expansion and contraction. Standing seam designs also eliminate 80% of the through fasteners found in other systems for greater weathertightness. Standing Seam II panels provide 24" width coverage with 2" high ribs – 3" including the seam. Minimum roof slope for the Standing Seam II roof panels is ¼ to 12.

Basic Use: A roof covering system for new or retrofit construction. A specially designed roof system combines AMS' Standing Seam II roof panel with a layer of rigid insulation board and a Multi-rib liner panel giving the interior a finished look with excellent insulating properties. Thermax rigid insulation is applied between the interior and exterior panels. A compressible blanket insulation (unfaced) 1" thickness before compression is located between the exterior panel and the rigid insulation (while optional, this insulation is highly recommended to minimize panel rumbling in high winds). An optional 3 mil (or equivalent) vinyl vapor barrier may be used between the liner panel and the rigid insulation.

Materials: Standing Seam II panels are available in 24 or 22 gage 50,000 psi in either G90 zinc-coated (galvanized) steel or aluminum-zinc alloy-coated (AZ50 or AZ55) steel. Pre-painted panels have Architectural Metal Systems' SmartKote (Kynar 500®) or Silicone Modified Polyester Finish.

The Multi-rib liner has 15/16" ribs with major corrugations spaced on 6" centers. They offer 36" width coverage.

Rigid insulation is Thermax® by Celotex Corporation, Types TF600, TF604, TF610 or Thermax Plus with a maximum thickness of 5-1/2" in a double layer or 4-1/2" in a single layer. Panel clips for the Standing Seam II roof panel are two part assemblies. The tab portion is 2-1/2" wide, die formed of SAE 1050 high carbon spring steel and heat treated to Rockwell 45C to 50C with fluorocarbon coating for corrosion resistance or 301 stainless steel. The base portion of the clip is 2-1/4" in height. It is die formed from 12 gage zinc-coated (galvanized) steel. Total expansion capability of the clip assembly is 2-1/2". For higher uplift value requirements, optional panel clip accessory, panel to clip fastening base (SSCH), which is 16 gage zinc-coated galvanized material is available. Bearing plates for the Standing Seam II panel clips are 20 gage zinc-coated (galvanized) or aluminum-zinc alloy-

coated steel. Standing Seam II sidelaps have factory applied mastic, SikaLastomer-511 or equal. Its composition is 85% solids by weight. Service temperature range is -60°F to +220°F.

Endlaps, roof flashing laps, ridges and eave closures are sealed with tape mastic, Sika Sika-Tape TC-95 or equal. The material is non-staining, non-corrosive, non-toxic and non-volatile. Composition is 100% solid isobutylene tripolymer tape. Service temperature range is -60°F to +212°F.

Eaves, endlaps, ridge and eave closures are sealed with non-skinning butyl caulk, SikaLastomer-511 or equal. Its composition is 85% solids by weight. Service temperature range is -60°F to +220°F. All gutter and downspout joints, and roof accessories are sealed with polyurethane caulk, Sika SikaFlex 219LM or equal. It meets or exceeds Federal Specification TT-S-00230C, Type II, Class A. All fasteners for panel to secondary framing and panel to panel will be one of the following EPDM washer head screws.

A. Premium roof fasteners shall be No. 14 x 1" self-drilling carbon steel screws with a molded zinc alloy hex washer head. Premium roof fasteners will be on all warranted roofs and all pre-finished roofs.

B. Standard roof fasteners shall be No. 14 x 1" self-drilling carbon steel screws with an integral hex washer head. Standard roof fasteners shall have a corrosive resistant coating over zinc plating. Standard roof fasteners shall be on unwarranted aluminum-zinc, alloy-coated roofs only.

Standing Seam II panel clips are attached to the purlins with self-drilling carbon steel screws No. 12 hex head, cadmium or zinc plated. The screw length is determined by the thickness of the rigid insulation.

Multi-rib panels are attached to the secondary framing members by self-drilling carbon steel screws, No. 12 x 1-1/4" hex head, cadmium or zinc plated. Panel sidelaps are stitched with self-drilling carbon steel screws No. 14 x 7/8" cadmium or zinc plated.

4. TECHNICAL DATA

The Standing Seam II panel has received a Class 90 Wind Uplift rating by Underwriters Laboratories when tested in accordance with test procedure UL 580. This panel has also been tested in accordance with Air Infiltration, ASTM E1680 and Water Penetration, ASTM E1646. This panel has received a Class A fire rating when tested in accordance with test procedure ASTM E108.

....continued

COMPOSITE ROOF SYSTEM WITH STANDING SEAM II

5. INSTALLATION

Installation should be performed in accordance with Architectural Metal Systems' manuals and building erection drawings, and should be by a qualified installer using proper tools and equipment. Systems are installed by Architectural Metal Systems Authorized Roofers.

6. AVAILABILITY

For availability, contact:

ARCHITECTURAL METAL SYSTEMS

7. WARRANTY

Thirty-five year material and twenty year weathertightness warranties are available.

8. MAINTENANCE

Only normal routine maintenance is required over the life of the panels.

9. TECHNICAL SERVICES

For information, contact:

ARCHITECTURAL METAL SYSTEMS

10. PRODUCT NOTES

A certain amount of waviness called "oilcanning" may exist in this panel. Minor waviness of the panel is not sufficient cause for rejection, because oilcanning does not affect the structural integrity of the panel.

Architectural Metal Systems reserves the right to revise all standard specifications and information. Architectural Metal Systems regularly updates its published "Standard Specifications" on the AMS web site, www.ametalsystems.com, which supercede and replace any previously published standard specifications of Architectural Metal Systems'.

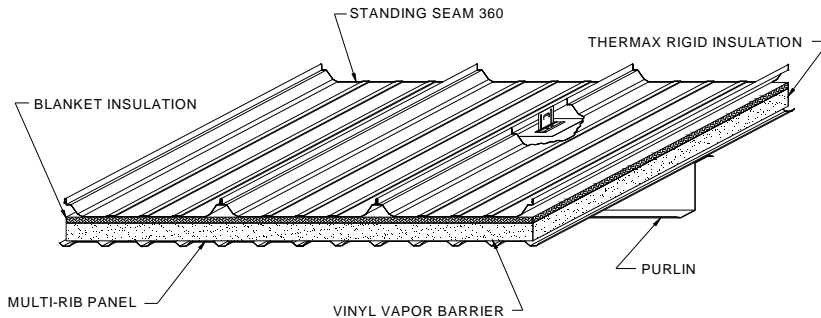

System "R" Values

	Thermax	Winter	Summer
1"		9.8	10.5
1 1/2"		13.8	14.1
2"		17.8	17.7
2 1/2"		21.8	21.3
3"		25.8	24.9
4"		33.8	32.1

Engineering Properties of Architectural Metal Systems Standing Seam II Panel

Designated Gage of Steel	Steel Yield KSI	Base Metal Thick. (In.)	Total Thick. (In.)	Panel Weight (lbs. / ft. ²)	Top In Compression			Bottom In Compression			Fb KSI
					lx	Sx	Ma	lx	Sx	Ma	
					(In. ⁴ / ft.)	(In. ³ / ft.)	K-IN.	(In. ⁴ / ft.)	(In. ³ / ft.)	K-IN.	
24 Ga.	50	0.0225	0.0241	1.20	0.276	0.111	3.33	0.129	0.079	2.37	30
22 Ga.	50	0.0300	0.0316	1.58	0.371	0.152	4.56	0.180	0.108	3.24	30

Gage of Panel	No. of Spans	Load Type	Maximum Total Uniform Load in PSF							
			Span Lengths, Ft.							
			1.50	2.00	2.50	3.00	3.50	4.00	4.50	5.00
24 Ga.	1	POS	734	460	313	225	169	132	105	86
	2	POS	549	339	228	163	122	95	75	61
	3	POS	634	401	274	198	149	116	93	76
	4	POS	608	381	259	187	140	109	87	71
22 Ga.	1	POS	1070	658	441	315	236	183	145	118
	2	POS	792	480	320	227	169	131	104	85
	3	POS	927	575	387	277	208	161	129	105
	4	POS	885	545	366	261	195	151	121	98

- The panels were checked for bending, shear, combined bending and shear, and deflection. Deflection was limited to span/150
- Section Properties have been calculated in accordance with the 2001 *North American Specification for the Design of Cold-Formed Steel Structural Members*.
- Minimum yield strength of 24 and 22 gage steel is 50,000 psi.
- Steel panels are either aluminum-zinc alloy or G-90 coated. The base metal thickness was used in determining section properties.
- Positive load (POS) is applied inward toward the panel supports and is applied to the outer surface of the full panel cross-section.

COMPOSITE ROOF SYSTEM WITH STANDING SEAM II

